



# Clean-in-place

Support guide

aerospace  
climate control  
electromechanical  
**filtration**  
fluid & gas handling  
hydraulics  
pneumatics  
process control  
sealing & shielding



# Parker domnick hunter Process Filtration

## Setting the standard

Parker domnick hunter brings extensive experience through our scientists, engineers and sales representatives to the process of offering specific filtration systems to meet the needs of your production process. Support services are available covering a wide range of activities including scale-up advice from laboratory through pilot scales to production systems, validation support on-site technical support, design and manufacturing of custom housings and filtration products.

### Committed to quality

Quality is of paramount importance to Parker domnick hunter. As such we have been certified to ISO9001, providing a quality management system that covers the entire organization including R & D, production, warehousing, materials management and customer support. In addition, our manufacturing facilities operate to the principles of cGMP.

Our manufacturing facilities are also certified to ISO14001 Environmental Management Standard and ISO13485 Medical Device requirements.

### Validation and product certification

To certify that Parker domnick hunter products meet the required regulatory and quality standards of the industries that we supply, all filters are supplied with a certificate of conformance. These certificates are linked to validation documents for both prefilter and sterilizing grade membrane filter products that define methodologies and data appropriate to each filter type. This information typically includes:

- Technical specifications.
- Biological safety testing information; USP <88> Class VI - 121C Plastics and equivalents.
- Extractable testing including 21CFR211.72 and 210.3(b), 6 for fibre release.
- Purified water filtration quality including TOC, bacterial endotoxins, conductivity and particle release.
- Chemical compatibility guidance information.
- Thermal stability.
- Correlation of an appropriate non-destructive integrity test to a defined bacterial challenge.
- EC Food contact safety specification.

### Validation support services

Parker domnick hunter has extensive laboratory facilities and trained personnel capable of providing a range of validation services to support manufacturers in meeting their requirements for process validation relating to the use of filtration products.



# Contents

<b>Parker domnick hunter Process Filtration</b>	<b>3</b>
<b>Clean-in-place</b>	<b>6</b>
<b>Usual suspects</b>	<b>7</b>
<b>Guideline parameters</b>	<b>8</b>
General	8
Water and cleaning solutions	8
Maximum differential pressure (dP)	9
When to clean	11
Compatibility	12
Integrity testing	13
<b>Clean-in-place procedures</b>	<b>14</b>
Cold water chase	16
Cold water rinse	16
Backwashing	17
Warm / hot water rinse	17
Chemical regeneration	18
Chemical sanitization	19
Hot water sanitization	20
Steam-in-place (SIP)	21
Autoclaving	22
Short-term storage	22
Long-term storage	23
Chemical regeneration at high dP (blocked cartridges)	23
<b>Regeneration examples</b>	<b>24</b>
<b>CIP approach</b>	<b>25</b>
<b>Process simulations</b>	<b>26</b>
<b>General</b>	<b>26</b>
<b>Technical Support Group activities</b>	<b>27</b>

# Clean-in-place

Successful and economic use of process cartridge filters is dependent upon employing correct procedures to ensure that the filters are not damaged and their lifetime in the application is maximized. Parker domnick hunter cartridges are designed to withstand adverse conditions of use, but by adhering to the following guidelines, the likelihood of premature blockage, integrity test failure and process stoppages will be reduced.

This document provides guidelines that are intended for incorporation into Standard Operating Procedures. Recommendations should be considered flexible and continuous monitoring should be carried out to improve the process as on-going experience is gained.

The following 4 guidelines are key to a good CIP practice:

- Good regular cleaning can greatly increase the life of a filter. Little and often is better than an occasional strong clean.
- Improving efficiency of cleaning can result in increased filter life.
- Effective sanitization is important to maintain product quality.
- Inappropriate cleaning regimes can damage filters.

The following three-stage filtration system (Figure 1) with ancillary supplies is used as an example throughout the document. Between 'process in' and 'process out' the 3 filter stages can be seen. Over each filter system it is recommended that the differential pressure (dP) be monitored and recorded by (automated) pressure sensors. The temperature should be measured and recorded downstream of the final filter. A CIP system (upper left) can provide flushing and cleaning of the system. A steam supply can be used to steam sterilize the filter system.

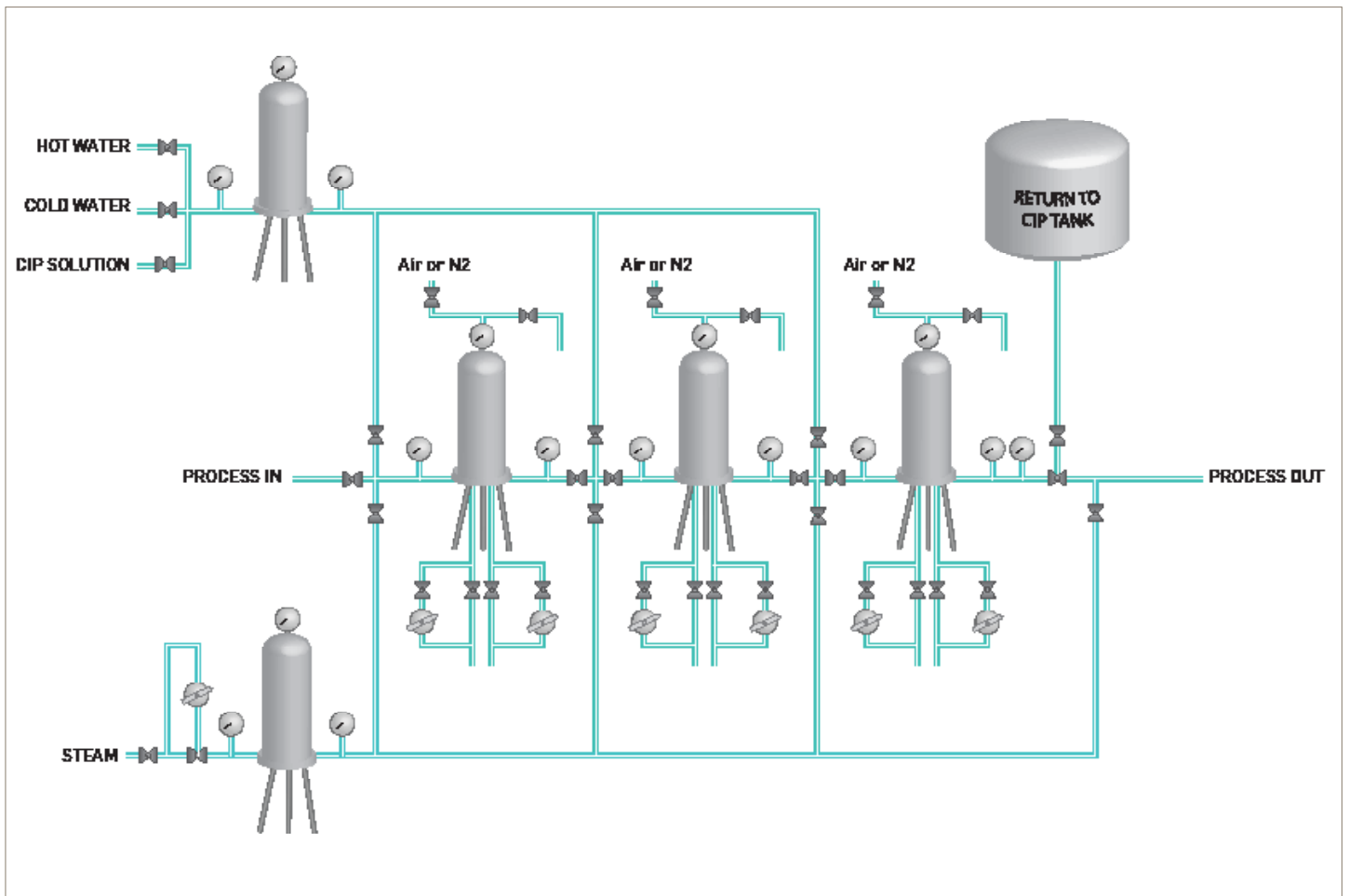
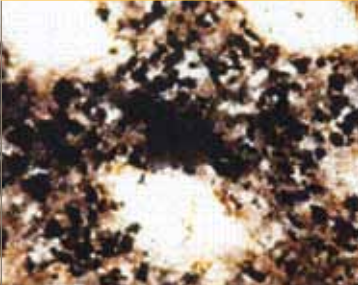
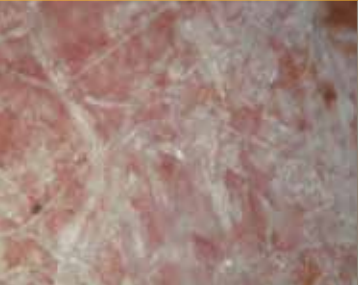
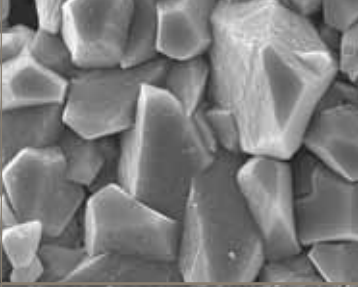
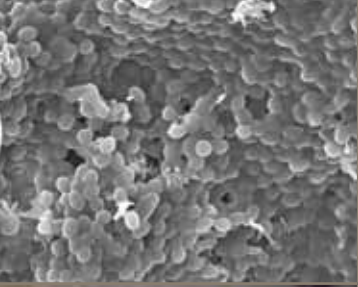
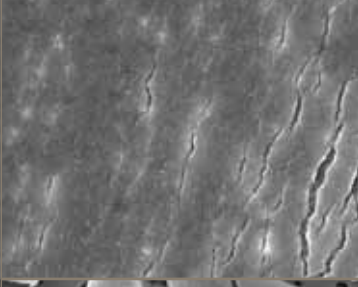

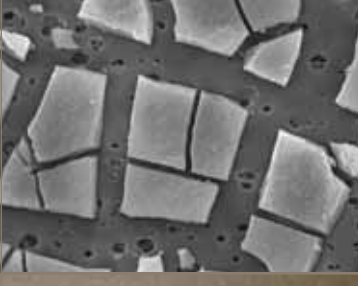
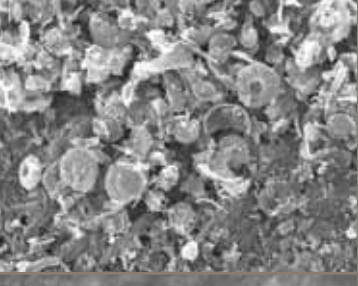

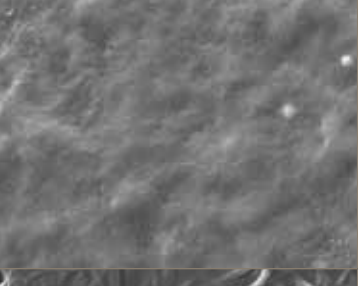
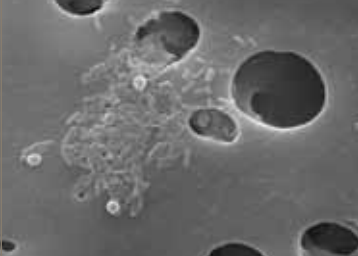
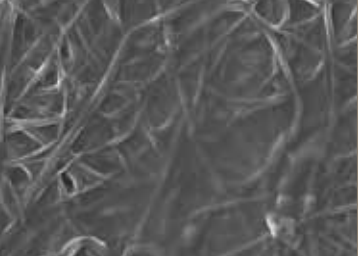

Figure 1 - Example three-stage filtration system

# Usual suspects

The following pictures show typical contaminants on filter medias in water, beer and wine applications.

Figure	Observation / comment	Figure	Observation / comment
	Microscope image of Carbon on process water filter from Carbon bed		Microscope image of yeast on wine prefilter
	SEM of scale on membrane filter for bottled water (Calcium scale)		SEM image of yeast on membrane filter in wine application
	SEM of Aluminium silicates (clay minerals) on bottled water final filter		Microscope image of PVPP on beer trap filter
	SEM image of scale on membrane filter for bottled water (Calcium - Magnesium scale)		SEM image of Diatomaceous earth on wine prefilter
	Microscope image of scale on membrane filter for bottled water (Ferric Iron / complexes from organic material with colloidal Iron)		SEM of beerstone on final filter
	SEM image of bacteria on bottled water final filter		SEM of CMC on wine prefilter

# Guideline parameters

## Water and cleaning solutions

All water and cleaning solutions should be prefiltered prior to contacting the process filters in order to avoid filter blockage occurring due to the CIP process. The protection offered to the process filters is greater if finer prefilters are used. The CIP filter rating chosen is dependent on the tightest micron rating of filters in the filter train that receives the CIP solution direct.

In the example filter train 10 micron PEPLYN HA – 1.0 micron PREPOR NG – 0.45 micron BEVPOR PH, if the CIP solution is brought first over the 10 micron filter followed by the other stages, then this filter will determine the retention rating of the CIP filter. However, if the cleaning solution is brought simultaneously over the 3 stages, then the filter for the CIP solution must be sufficiently fine to protect the finest pore size of the process filters. In the example that is the 0.45 micron BEVPOR PH filter.

The following guidelines can be used:

- When cleaning depth (media) filters, use a depth filter with a micron rating of up to two grades higher. For example, a 20 micron PEPLYN PLUS CIP prefilter for a 10 micron PEPLYN PLUS process filter.
- If back-washing a depth filter that is suitable for back flushing, use the same grade or finer for prefiltration purposes to avoid contaminating the downstream side of the filter being back-washed.
- When cleaning membrane final filters directly, prefilter using a media cartridge with an absolute rating one grade higher or a membrane filter up to two grades higher. For example for a 0.45 micron BEVPOR PH filter, use a 0.6 micron PEPLYN PLUS.

In both cases, assess performance with time in order to optimize the lifetime to blockage of the individual stages.

Cleaning solutions should be freshly prepared.

Conductivity of cleaning solutions can be monitored to ensure that the correct concentrations are used. Suppliers of cleaning solutions can provide information on conductivity values relative to concentration.

## Gradual temperature

<b>Temperature</b>	Gradual changes, no shock
<b>Cold</b>	4 °C to 30 °C (i.e. ambient)
<b>Warm</b>	40 °C to 60 °C
<b>Hot</b>	60 °C to 95 °C
<b>Duration</b>	15 to 30 minutes at required temperature
<b>Flow rate</b>	Ideally 20% of process flow rate
<b>Direction</b>	Forward direction unless back flush on trap filter
<b>Back flush</b>	Up to 1.5 times the process flow

## Maximum differential pressure (dP)

### What is differential pressure?

- Differential pressure is the difference between two points in a system. In a filtration system, the differential pressure is the pressure between the upstream side of a filter and the downstream side of a filter.
- Differential pressure is directly proportional to flow rate (Where velocity does not limit flow).

The following example shows the differential pressure over a two-stage system:

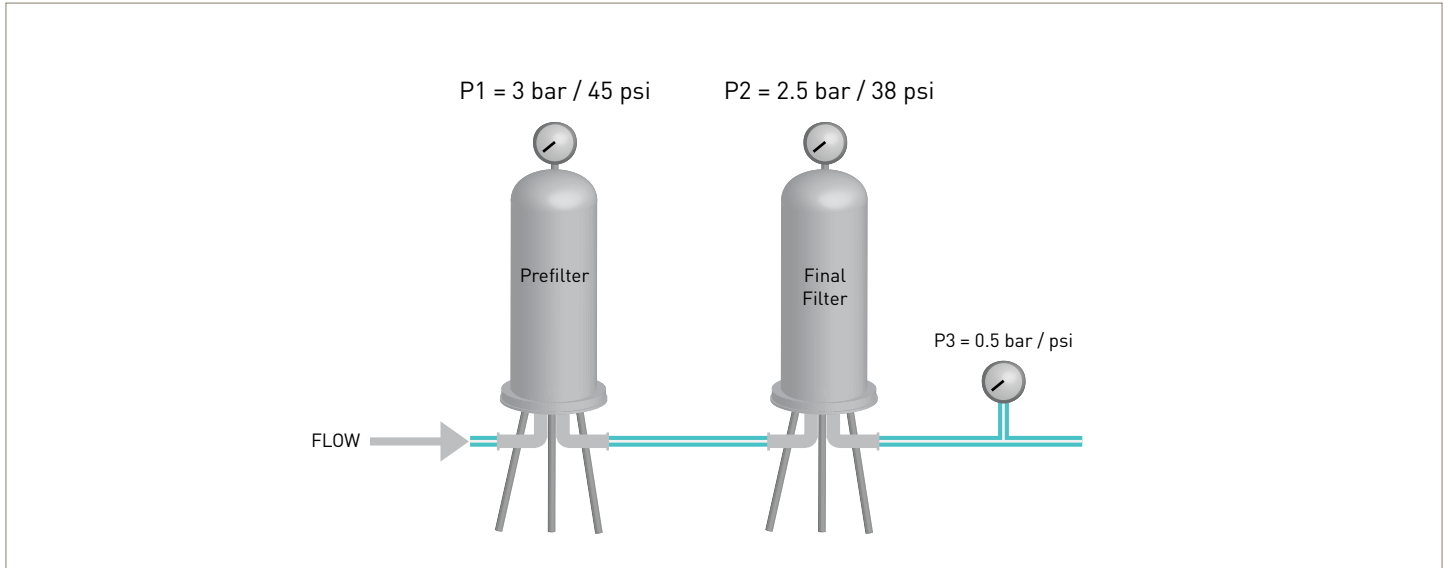

Figure 2 - Differential pressure over a two-stage system

	Prefilter	Final filter
Differential pressure (dP)	$P1 - P2 = 0.5 \text{ bar}$	$P2 - P3 = 2.0 \text{ bar}$

### Relationship between dP and blockage:

If it is assumed that blockage is a constant process. Then when the available surface area is 50% blocked the differential pressure is increased by a factor of 2.

This is due to the fact that the same flow rate is being processed through an area half of the original filter surface area. This is shown in the following graphs.

There are 60 particles in 1L Flow rate through 120 pores = 1 L/min (8.3 mls/min/pore)	Flow rate through 60 pores = 1 L/min (16.6 mls/min/pore)	Flow rate through 30 pores = 1 L/min (33.3 mls/min/pore)	Flow rate through 15 pores = 1 L/min (66.6 mls/min/pore)
Clean differential pressure = 100 mbar	Differential pressure = 200 mbar	Differential pressure = 400 mbar	Differential pressure = 800 mbar

With this data a typical blockage curve can be drawn:

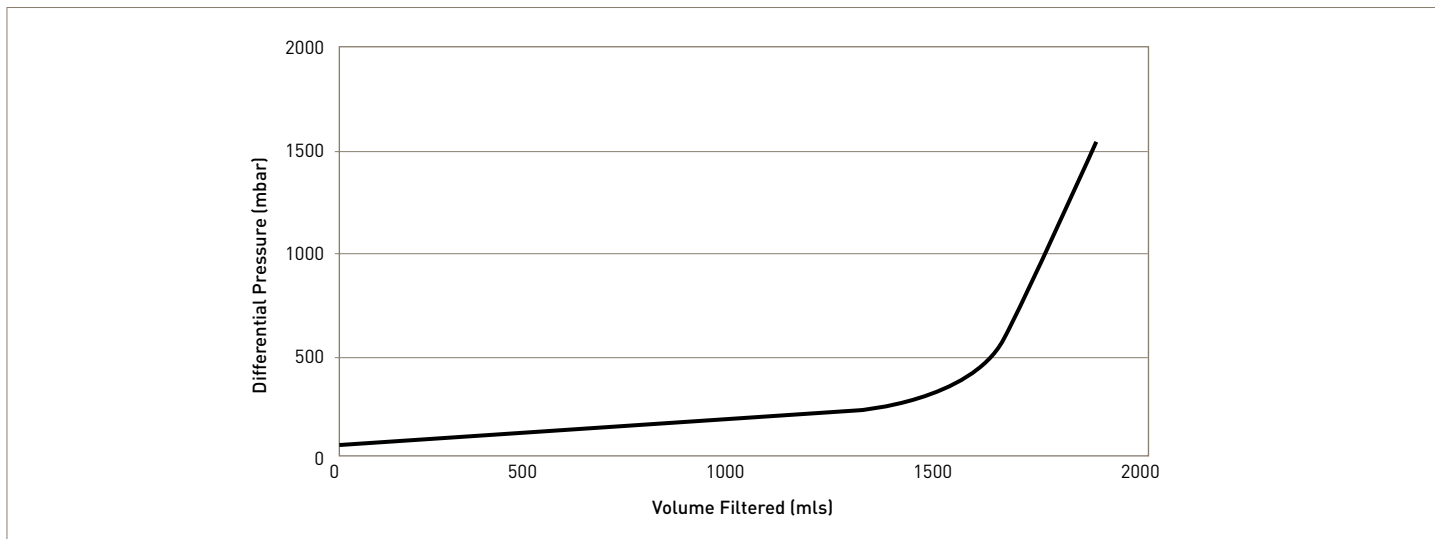

Figure 3 - Typical blockage curve

### Depth (media) filters

Temperature	Maximum dP (bar)	
	Forward flow	Reverse flow*
20	5	2.0
40	4	1.5
60	5	1.0
80	2	0.5
90	1	Not recommended
>100 (Steam)	0.3	Not recommended

Table 1 - Maximum recommended differential pressure over depth filters

\*Reverse flow is only recommended for PEPLYN Polypropylene depth (media) filters. Back washing clarification filters is a generally accepted technique and some filters, such as PEPLYN HA, have been specifically designed to improve the efficiency of the back-wash operation.

Always consult individual cartridge specification before adopting backwash cleaning. Close control of the conditions is required, although PEPLYN products are robust and will accept some abuse.

### Membrane filters

Temperature	Maximum dP (bar)
	Forward flow
20	5
40	4
60	5
80	2
90	1
>100 (Steam)	0.3

Table 2 - Maximum recommended differential pressure over membrane filters

Back washing of membrane filters is not recommended.

## When to clean ?

Cleaning frequency can be based on time or blockage. As blockage occurs exponentially, filters should be cleaned before rapid, unrecoverable blockage occurs.

Typically CIP should be conducted when a rise in the dP starts to occur (ideally when the dP rises above 100 to 200 mbar over the starting dP at process flow rate with clean filters) to remove blockage particulate and prolong the lifetime of the filters.

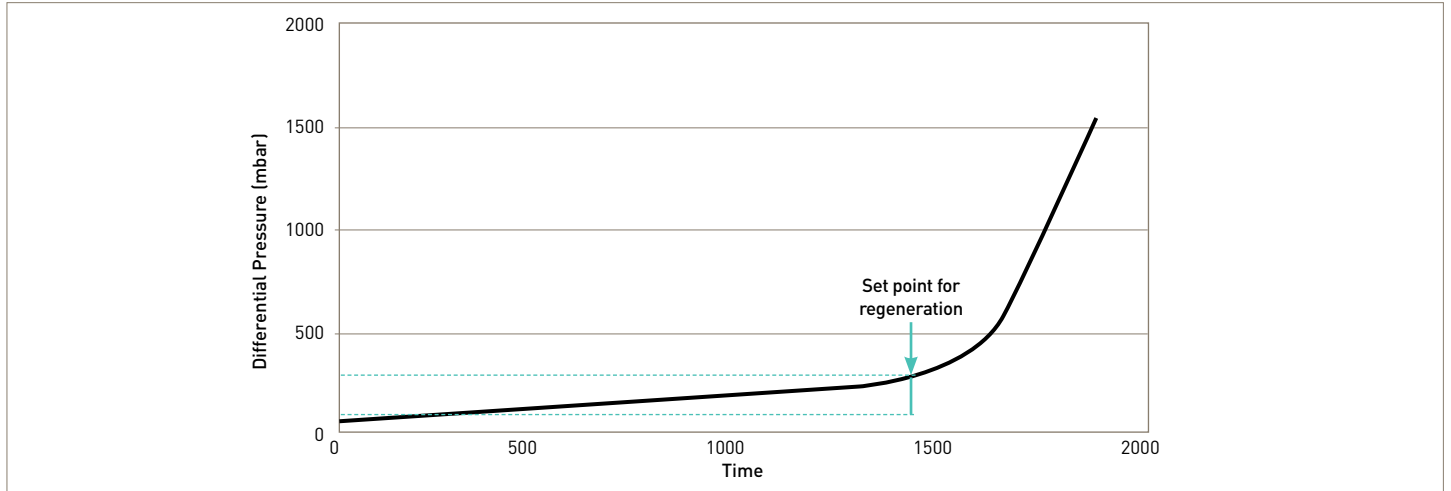

Figure 4 - Example of when to perform a CIP

CIP can also be based on time, for example weekly to control microbial levels or can be performed between batches. Good regular cleaning can greatly increase the life of a filter resulting in improved economics. Little and often (figure '4A') is better than an occasional strong clean (figure '4B'). This is shown in following 2 figures:

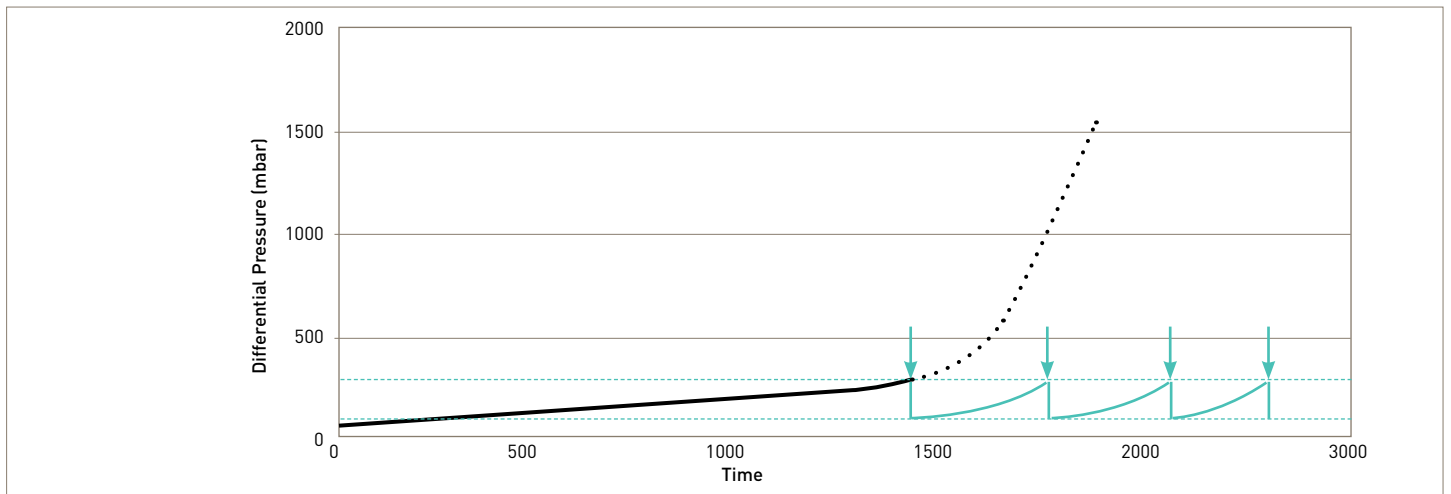

Figure 4A - Example of regular clean extending life to blockage

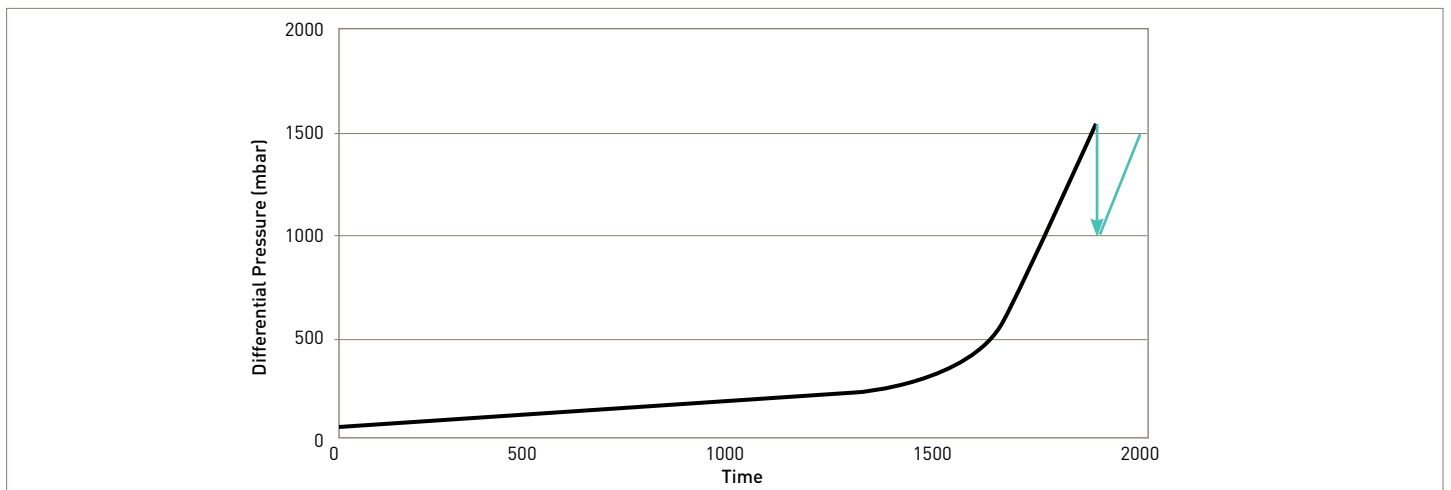

Figure 4B - Example of occasionally strong clean not reducing dP | 11

## Compatibility

Before using any chemicals, check the compatibility of the filter prior to use. If in doubt, contact Parker domnick hunter. As Parker domnick hunter exercises a policy of continual product development cartridge specifications may change, however, the general guidelines below can be applied.

Active agent	Condition*	Parker domnick hunter Product	Guideline cumulative contact time
Hot water	85 °C	BEVPOR	1000 hours <sup>1</sup>
		PEPLYN	245 hours <sup>1</sup>
		GF, GP	100 hours <sup>2</sup>
Steam	121 °C	BEVPOR	25 hours <sup>2</sup>
		PEPLYN	100 hours <sup>2</sup>
		GF, GP	10 hours <sup>2</sup>
Caustic (NaOH) in a buffered sanitizer	0.352% NaOH (and <0.6% EDTA) @ 60°C	BEVPOR	336 hours <sup>3</sup>
	0.352% NaOH (and <0.6% EDTA)	BEVPOR, PEPLYN	>1000 hours <sup>3</sup>
		GF, GP	18 hours <sup>2</sup>
Peracetic Acid (PAA)	0.54% PAA (and <0.54% H <sub>2</sub> O <sub>2</sub> , <0.54% AA)	BEVPOR	>1000 hours <sup>3</sup>
	0.15% PAA (and <0.15% H <sub>2</sub> O <sub>2</sub> , 0.15% AA) @ 50°C	BEVPOR	240 hours <sup>4</sup>
	0.05% (500 ppm) PAA	GF, GP	168 hours <sup>2</sup>
Hydrogen Peroxide (H <sub>2</sub> O <sub>2</sub> )	0.15% H <sub>2</sub> O <sub>2</sub> @ 50 °C	BEVPOR	600 hours <sup>4</sup>
	0.4% H <sub>2</sub> O <sub>2</sub> (and <0.13% AA, <0.1% PAA)	BEVPOR	600 hours <sup>4</sup>
	0.2% H <sub>2</sub> O <sub>2</sub> (and <0.065% AA, <0.1% PAA) @ 50 °C	BEVPOR	240 hours <sup>4</sup>
Phosphoric (H <sub>3</sub> PO <sub>4</sub> ) / Nitric (HNO <sub>3</sub> ) Acid	1% HNO <sub>3</sub> and 1% H <sub>3</sub> PO <sub>4</sub> @ 55 °C	BEVPOR	256 hours <sup>5</sup>
Sulphur Dioxide (SO <sub>2</sub> )	2% SO <sub>2</sub>	BEVPOR	168 hours <sup>2</sup>
	0.5% SO <sub>2</sub>	BEVPOR, PEPLYN, GF, GP	756 hours <sup>2</sup>
Chlorine Dioxide (ClO <sub>2</sub> ) Sodium Hypochlorite	10ppm free Cl	BEVPOR, PEPLYN	336 hours <sup>9</sup>
	1700ppm total Cl	BEVPOR	>1000 hours <sup>10</sup>
Chlorinated Alkaline	<500ppm Chlorine (<0.15% KOH) @ 50°C	BEVPOR	72 hours (at least) <sup>8</sup>

\*All conditions at ambient (25 °C) unless otherwise stated.

References: 1 = T6562, 2 = Beverage Cleaning Guidelines (2003), 3 = T9122, 4 = T9123, 5 = T8716, 7 = T9146, 8 = T8983, 9 = T7439, 10 = VSG9256/TR13341.

### Notes:

The guidelines are based on tests with chemicals from commonly used industry suppliers and the concentrations are based upon the information in the TDS / MSDS.

Testing was conducted using clean, unused filters in controlled laboratory conditions and therefore, can not simulate the effects caused by use in applications where the filter componentry may be weakened by: prolonged exposure to aggressive process liquids and exposure to high dP through blockage or high flow.

It is recommended to regularly integrity test (for example weekly) the filters in processes to check their performance. Integrity testing will enable the user to verify that no filter damage has occurred during storage, installation or following procedures such as chemical cleaning prior to use or during the subsequent manufacturing process.

# Integrity testing

Most membrane filters can be tested to ensure that they are integral before use. This should always be carried out to ensure that the cleaning procedures have not damaged the cartridges in any way. Detailed integrity test procedures and training are available on request.

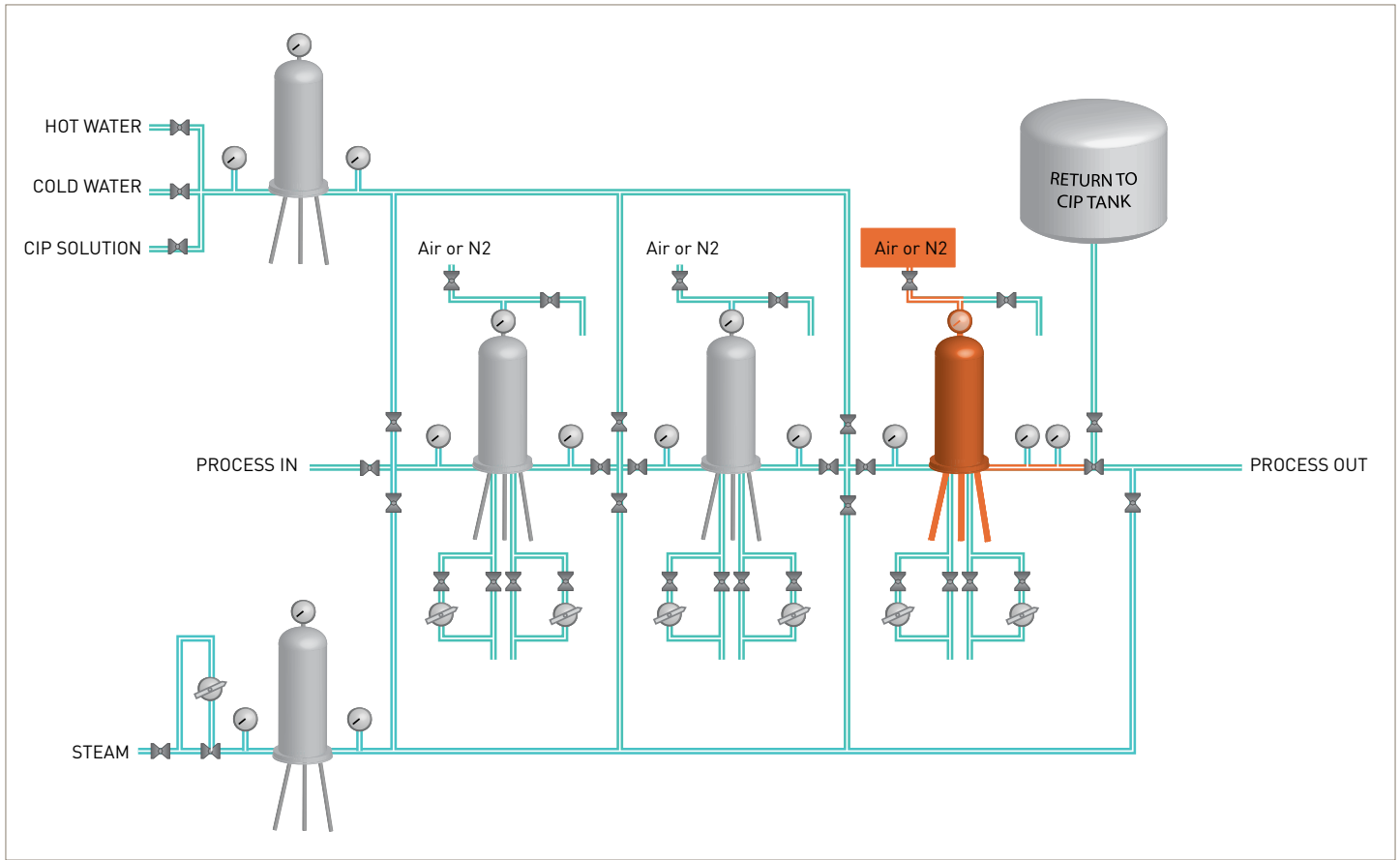

Figure 5 - Filtration system with recommended integrity test connections

# Clean-in-place procedures

Procedure	When	Frequency	Recommendations		
			Temperature °C	Duration (mins)	Flow (% of process flow rate)
Cold water chase	End of batch, change of product	N/A	5-30	5	20
Cold water rinse	Change of product, regeneration / IT	Daily	5-10	10	20
Back washing	Regeneration	Daily, weekly	5-30	10	150-200 reverse
Warm or hot water rinse	Change of product, regeneration	Daily	40-80	10	20
Chemical regeneration	Change of product, regeneration	Daily, weekly	20-60	20	20 Soak after 5 mins
Chemical sanitization	Sanitization	Daily, weekly	20-60	20	20 Soak after 5 mins
Hot water sanitization	Sanitization	Daily, weekly	80-90	20	20
Steam-in-place	Sanitization	Daily, weekly	105-130	20	Very low steam flow
Autoclaving	Sanitization	Prior to storage	121	20	N/A
Short-term storage	Storage	-	20	N/A	N/A
Long-term storage	Long-term storage	-	20	N/A	N/A

Table 3 - details on CIP procedures

To avoid the transport of particles from the prefilters to the final filter, the cleaning solution over a filter should always be drained whilst that filter is being rinsed. When the cleaning solution at the drain runs clear the inlet to the next filter can be opened and the drain closed so the cleaning solution flows to the next filter. This procedure is shown in Figures 2, 3 and 4.

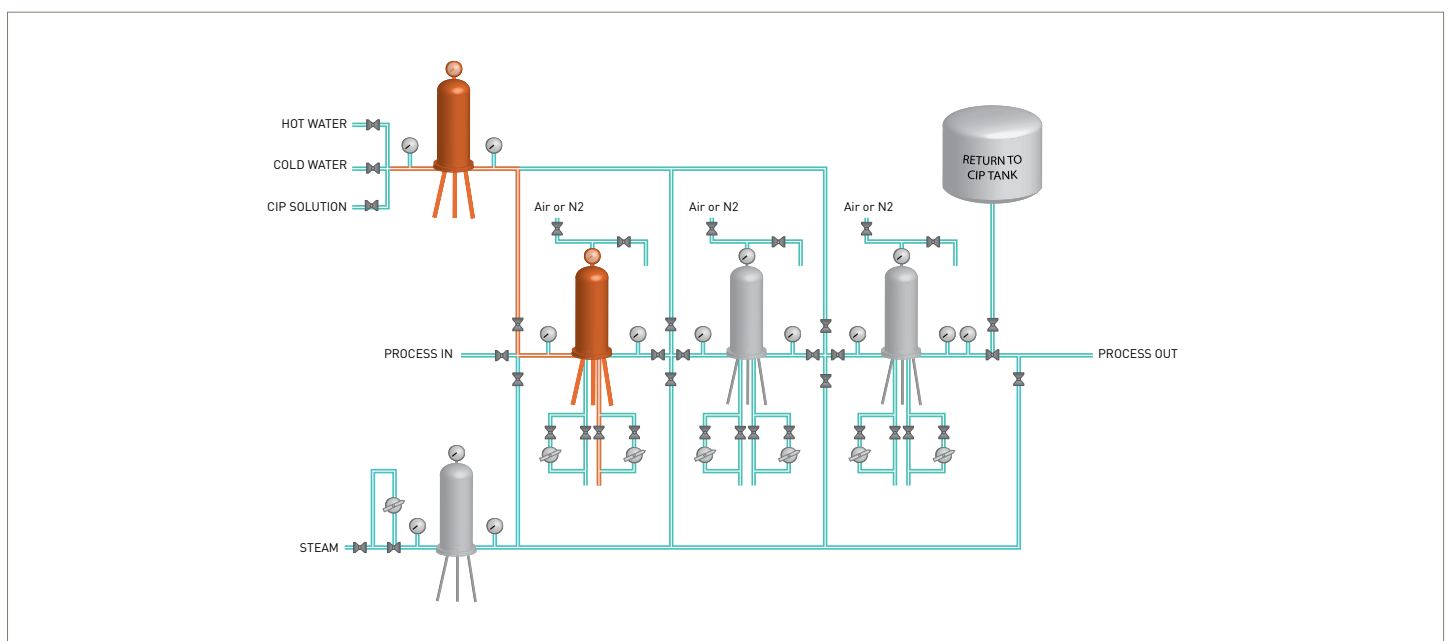

Figure 6 - Forward rinse/clean of the first filter stage

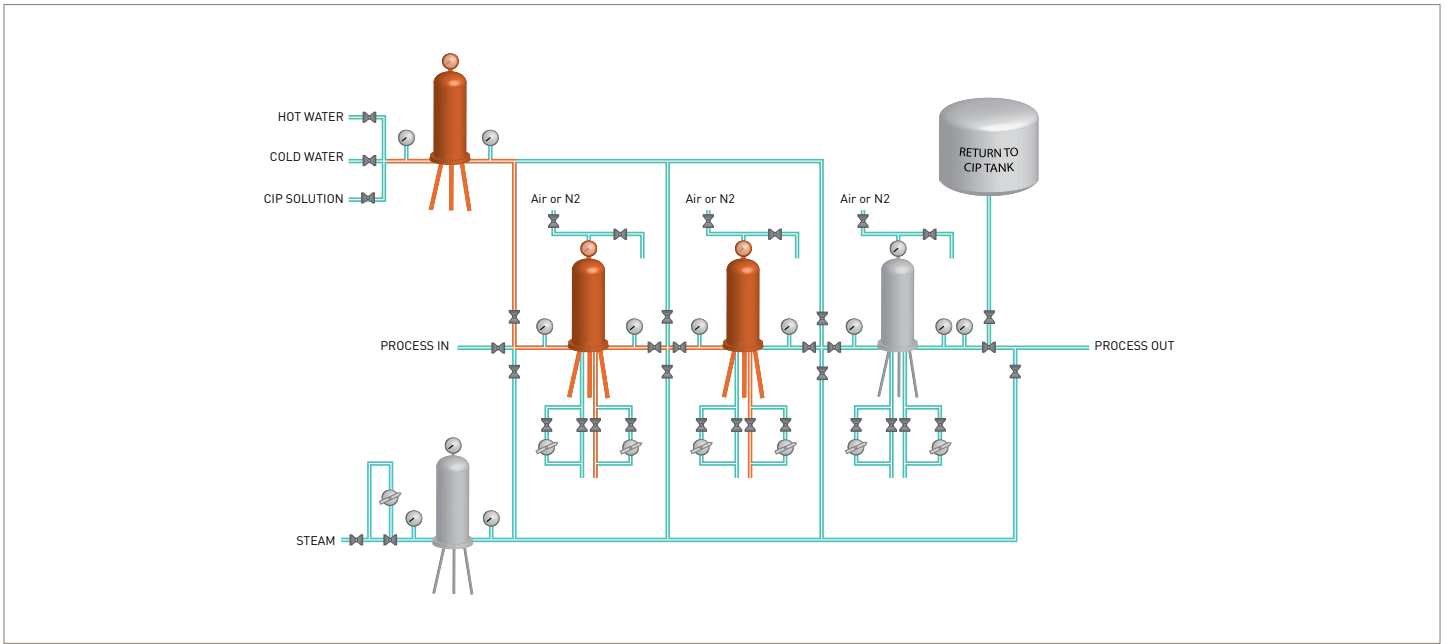

Figure 7 - Forward rinse/clean of the second filter stage

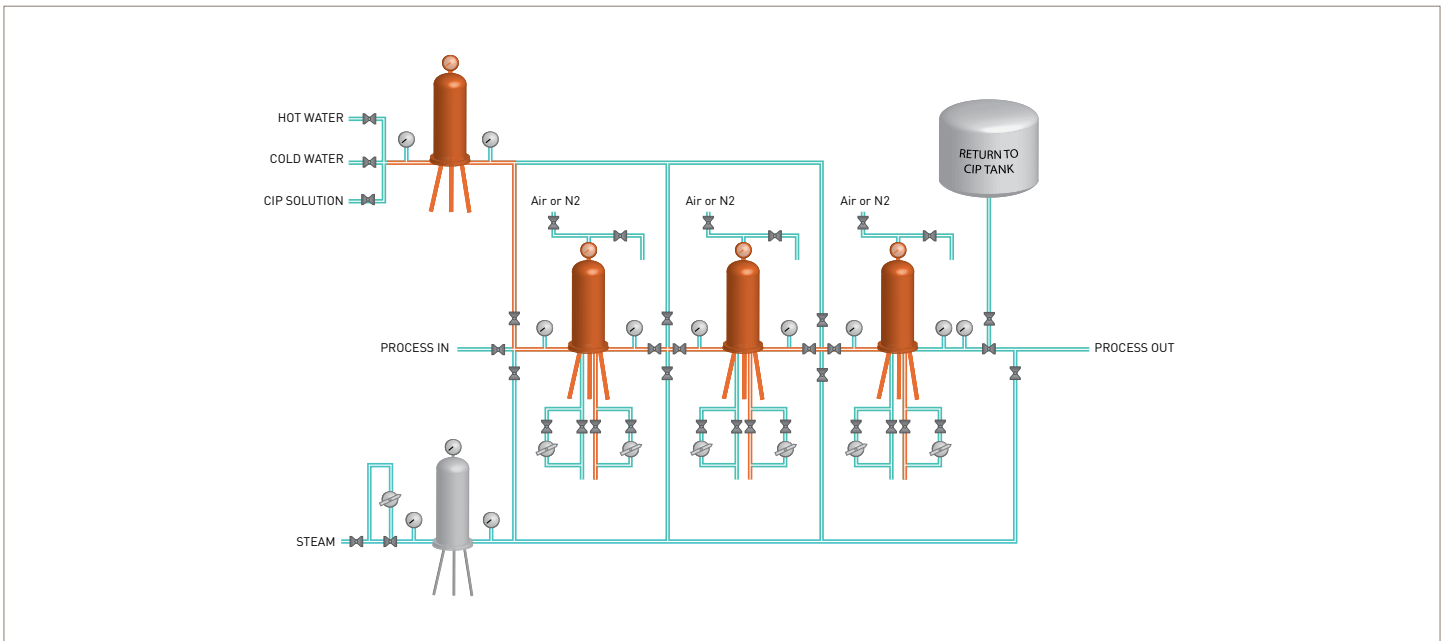

Figure 8 - Forward rinse/clean of the third filter stage

Alternatively during any rinsing or cleaning period, filter stages can be cleaned simultaneously. The advantage of rinsing simultaneously is that the overall cleaning time can be reduced, however, if this is carried out the prefilter for the water (or CIP solution) must be sufficiently fine to protect the finest pore size of process filter. This is shown in the following figure (figure 5).

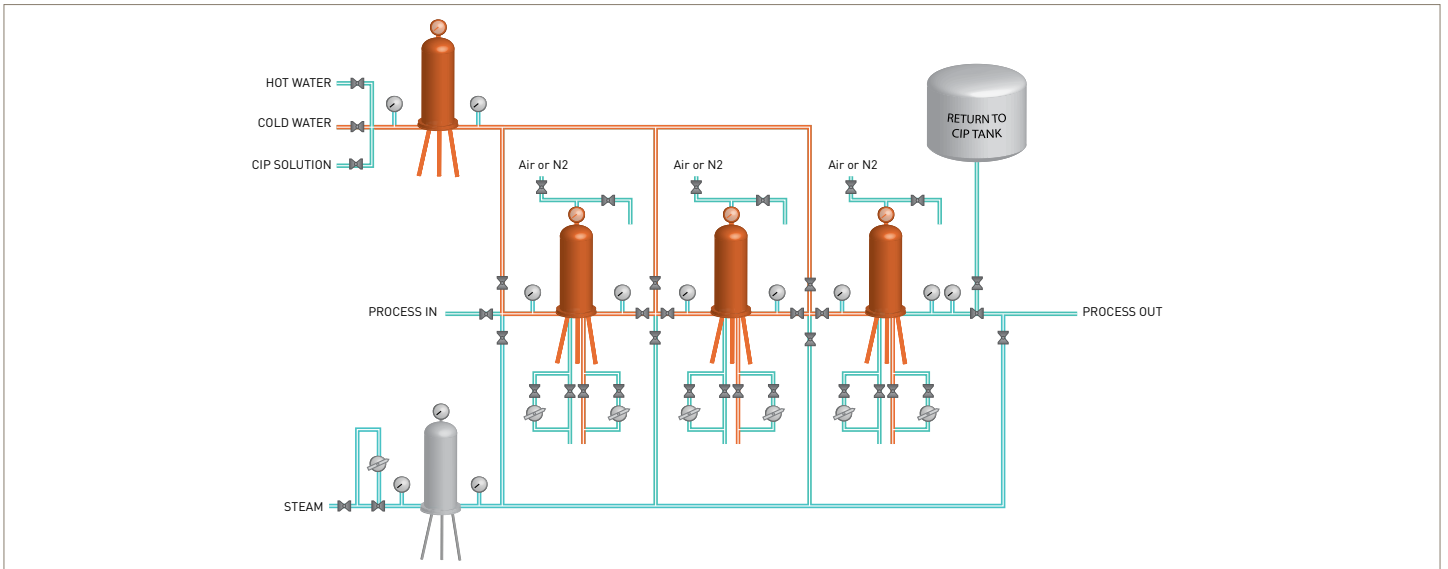

Figure 9 - Simultaneous rinse/clean of the three filter stages

## Cold water chase

This is a cold water flush carried out to push product out of the line. It is often controlled manually by observing the change from product to water through a sight glass, or by on line conductivity measurement. It is carried out to maximize the volume of product transferred, but also to ensure that water-insoluble species are pushed through the media in the process liquid, thereby preventing them from binding to the filter media and causing premature blockage.

Conditions	
Temperature	5 °C to 30 °C
Duration	Maintain for 5 minutes
Flow rate	20% of process flow rate
Procedure	
Cold water flush to package or transfer tank	
Stop when clean water is detected in downstream sight glass or by change in conductivity	

## Cold water rinse

This is a general rinse to clear the filters of product and water soluble blocking materials, or cleaning agents or before first use to ensure that no debris is in the filter after installation. This step is also used to wet out filters for integrity testing.

Conditions	
Temperature	5 °C to 30 °C
Duration	Maintain for 5 minutes
Flow rate	20% of process flow rate
Procedure	
Isolate housings	
Flush to drain until clear in first housing	
Open the inlet to the next housing and close the drain	
Repeat for all housings in series	
Rinse all housings simultaneously for the specified time	
Drain the system or proceed to next operation	

## Back washing

Back washing can be carried out as part of any of the rinsing or cleaning procedures. Back wash is usually only effective for prefiltration stages and, the chance of damaging membrane filters is very high.

The flow rate used during backwashing should be as high as possible without exceeding the recommended maximum differential pressure of the cartridge. In small systems this is often possible. In larger systems, pump capacity may limit the flow. As a guideline, a flow rate of 1.5 to 2 times the process flow rate is recommended.

Conditions	
<b>Temperature</b>	5 °C to 30 °C
<b>Duration</b>	Maintain for 10 minutes
<b>Flow rate</b>	150 - 200% of process flow rate, reverse flow

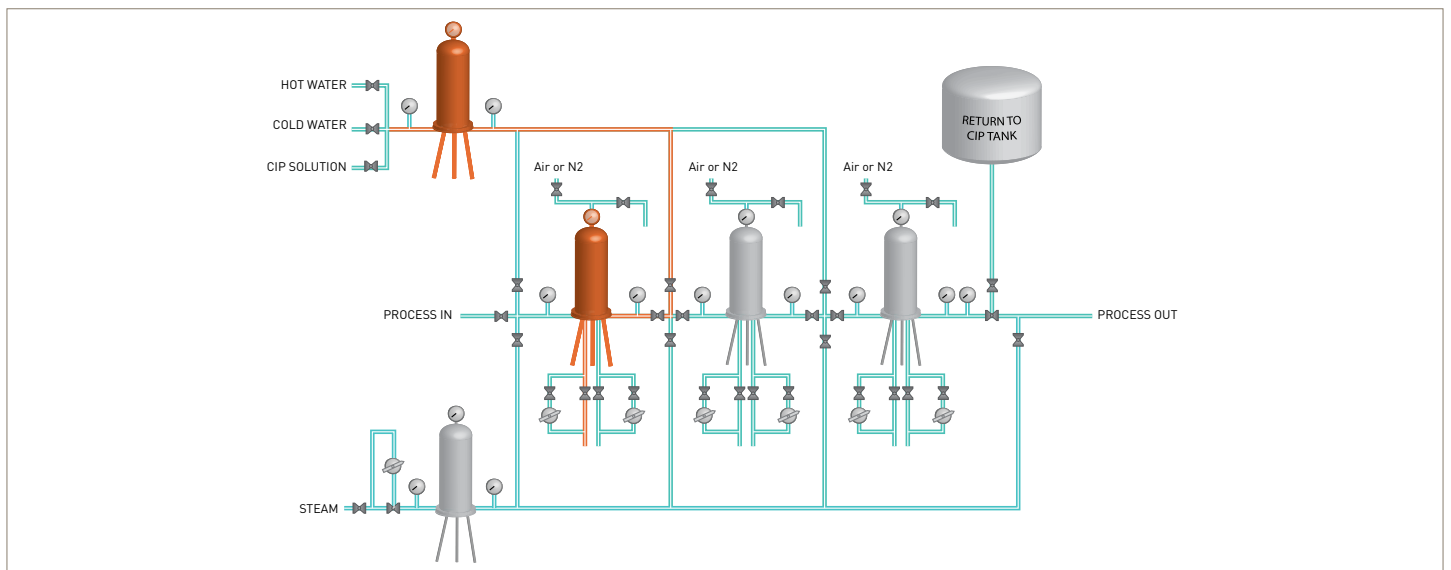

Figure 10 - Simultaneous rinse/clean of the three filter stages

## Warm / hot water rinse

Again this is a general rinse to further clear the filters of product and water soluble blocking materials. This procedure can also serve to gradually increase the temperature of the filter in preparation for hot water sanitization or steam sterilization.

Conditions	
<b>Temperature</b>	40 °C to 80 °C
<b>Duration</b>	Maintain for 10 minutes
<b>Flow rate</b>	20% of process flow rate

Procedure	
Isolate housings	
Introduce warm or hot water to the cold water contained in the first filter housing	
Flush to drain until clear in first housing	
Open inlet to next housing and close the drain	
Repeat for all housings in series	
Rinse for specified time	
Drain the system or proceed to next operation	

## Chemical regeneration

Chemical cleaning is performed to remove blocking materials that are not removed by water rinses, e.g. colloidal iron complexed with organic material, scales, trapped proteins, sugars, CMC. This can provide regeneration of the filters. The CIP could effectively increase the life to blockage of the filter by removing some of the contamination from the filter media. This can be enhanced by introducing a specific regeneration procedure.

The procedure can be simplified if the filter is compatible with chemicals already in use for other clean-in-place purposes. However, incorporating the filter CIP with a full system CIP may be false economy, as debris washed from the inner surfaces of lines and fittings may block the filter. Therefore it is recommended to prepare fresh cleaning chemicals for cleaning filters.

Conditions	
<b>Temperature</b>	20 °C to 60 °C
<b>Duration</b>	Maintain for 20 minutes
<b>Flow rate</b>	20% of process flow rate 5 mins Soak for 15 mins

Procedure
Cold water rinse
Warm or hot water rinse
Make up the required CIP solution
Isolate housings
Introduce CIP solution to the first filter housing
Flush to drain until clear in first housing
Open inlet to next housing and close the drain
Repeat for all housings in series
Circulate or stand for required duration
Drain the system or proceed to next operation

The advantage of carrying out the filter CIP in series through all of the filters is that the CIP solution is filtered by the existing process prefilters. In some circumstances it may be advisable to CIP each filtration stage separately, for example, if colour is not a good indicator of CIP solution cleanliness then apparently clean solution from the first filter may contain enough partially dissolved species to block the next filter. If the stages are cleaned separately then the prefilter for the CIP solution must be chosen so as to offer full protection to the tightest filter in the system.

## Chemical sanitization

Particularly when steam is not available elevated temperature sanitization may be supported by chemical sanitizers. The following sanitizers can be used:

Solution	Concentration	Comments
Alcohol	75 % ethanol in water	Also has some regenerative effect.
Hypochlorite	150 ppm (initial) 50 ppm (long term)	May lead to flavour taints as difficult to rinse.
Sulphur dioxide	2 % in water	Only usable in sealed vessels due to liberation of gas into the atmosphere.
Peroxyacetic acid	500 ppm (initial) 100 ppm (long term)	Smells like vinegar but easily rinsed and small quantities quickly dissipate, usually leaving no flavour or odour taints.
Proprietary disinfectants	As manufacturers' instructions	Examples - Divosan Active, P3- Oxona Active.

Conditions	
<b>Duration</b>	Maintain for 20 minutes
<b>Flow rate</b>	20% of process flow rate 5 mins Soak for 15 mins

Procedure
Cold water rinse
Warm or hot water rinse
Make up the required CIP solution
Isolate housings
Introduce CIP solution to the first filter housing
Flush to drain until clear in first housing
Open inlet to next housing and close the drain
Repeat for all housings in series
Circulate or stand for required duration
Proceed to next operation

## Hot water sanitization

Hot water sanitization is no more than a continuation of the hot water rinse, although the necessity for flow is only to ensure that all parts of the system reach specified temperature for the required duration. The effectiveness of the procedure is enhanced by leaving the filter housing full of hot water and allowing it to cool naturally.

The following conditions are usually satisfactory to ensure adequate system and filter sanitization on a daily basis:

Conditions	
<b>Temperature</b>	80 °C to 90 °C (85 °C recommended)
<b>Duration</b>	Maintain for 15 to 30 minutes (20 minutes at 85 °C recommended) then close off housing and allow to cool down
<b>Flow rate</b>	20% of process flow rate gentle flow to drain or circulation to stabilize temperature throughout the system
Procedure	
Isolate housings	
Slowly introduce hot water to the cold water remaining in the housing from the previous step. This will ensure that the temperature increase is gradual, reducing thermal shock of the filters.	
Flush to drain until clear in first housing	
Open the inlet to the next housing and close the drain	
Repeat for all housings in series	
Rinse all housings simultaneously for the specified time ensuring that the housings are at the specified temperature for the duration of the rinse (use temperature probes, temperature stickers on housings)	
Isolate housings and allow to cool naturally or proceed to next operation	

## Steam-in-place (SIP)

Steam will effect a more efficient sanitization than hot water. By adopting the recommended temperature and duration, a properly designed system will be sterilized to standards accepted within manufacture of pharmaceuticals. The drawbacks are the availability of steam in some facilities, the additional management of the process and the corrosive and erosive effects on the filter, which may lead to shortened operational life. Where full sterility is required, or where hot water sanitization alone is known to be insufficient:

Conditions	
<b>Temperature</b>	105 °C to 130 °C (121 °C recommended)
<b>Duration</b>	Maintain for 15 to 30 minutes (20 minutes at 121 °C recommended)
<b>Flow rate</b>	Minimal - controlled by 'cracked' valve, orifice plate or steam trap
Procedure	
Cold water rinse	
Warm or hot water rinse	
Steam through filters in series or steam individual stages separately or steam final filter stage only	
Allow pressure and temperature to rise and fall slowly	
Close downstream valves as pressure approaches 0 barg (100 °C)	
Allow temperature to drop to 50 °C to 60 °C	

Minimal steam flow should be used, controlled through 'cracked' valves, steam traps or an orifice plate directed to drain. It is good policy to keep all external valves slightly 'cracked'. This helps prevent air traps, condensate build-up and helps to sterilize the valve itself. Good steam quality and condensate management are essential to protect the filter. Use of chemical CIP between the cold and hot water rinses will aid the SIP process by washing away contamination that may otherwise be 'baked' onto the filter by the steam. Cooling after steaming may be accelerated by flowing compressed gas across the upstream side of the cartridges (take care not to exceed maximum differential pressure).

See Application Support Document - Steam-In-Place for more information.

## Autoclaving

Filter cartridges may be removed from their housings and steam sterilized in an autoclave. This would not normally be carried out as a regular procedure unless the process is prone to regular microbial contamination and on-line steam is not available. If this is the case, then when the filters are removed, the remaining system may be hot sanitized with over-strength chemicals which would otherwise damage the filter.

Procedure
Cold water rinse
Warm or hot water rinse
Chemical regeneration if needed
Cold water flush
Remove the cartridges from the housings with care
Place cartridges in an autoclave bag if possible
Place the cartridges on their side in the autoclave
Autoclave the cartridges on a 121 °C liquid cycle
When autoclave can be opened, immediately seal the autoclave bags if the cartridges are to be stored
Check o-rings prior to re-installation

## Short-term storage

If the filters are not to be used straight away for filtering the next batch of product but will be used in the next 1 to 4 days or within a month, then it is recommended to store the filters in an appropriate medium to prevent microbial growth in the storage solution.

Before short-term storage the filters need to be sanitized (see hot water sanitization, chemical sanitization and SIP for more information).

After the sanitization of the filters, the filters can be stored in the following solutions.

Solution	Concentration	Comments
Peroxyacetic acid	100 ppm	Up to 24 hours
Peroxyacetic acid	500 - 2000 ppm	1-4 days
Hydrogen peroxide	500 - 2000 ppm	4 days - 1 month Refresh solutions every 7 days
Citric acid / $K_2S_2O_5$	1000 - 2000 ppm	Up to 30 days
Nitrogen blanket	Pure - pressure 1 - 1.5 barg	Up to 30 days Check pressure regularly

## Long-term storage

For long-term storage (longer than 1 month) it is recommended to remove the cartridges from their housings. Care should be taken to ensure that they are placed in an area where they can not be damaged. If possible, they should be autoclaved or dried and placed in their original packaging for protection. Alternatively, the cartridges may be left in their housings or in a soak bath with suitable chemical sanitizer.

Procedure
Cold water rinse
Warm or hot water rinse
Chemical regeneration if needed
Chemical sanitization, hot water sanitization or SIP
Cold water flush or allow filters to cool to below 40 °C
Remove the cartridges from the housings with care

After these procedures have been carried out, either autoclave the cartridges, dry them for a few hours at a temperature of 50 °C to 60 °C in a convection oven, or place them in a soak bath. If the latter is chosen, the chemical solution should be changed regularly according to the manufacturer's instructions.

If drying can not be achieved, storage in one of the following solutions:

- 70% ethanol.
- 0.1 % citric acid /  $K_2S_2O_5$ , refresh the solution every 20 days.
- 50 ppm hypochlorite, refresh solution weekly or when below 40 ppm (test kits available from cleaning solution manufacturer).
- Specified storage solutions by the cleaning solution manufacturer. The chemical solution should be changed regularly according to the manufacturer's instructions. Please contact domnick hunter Process Filtration for compatibility information.

Solution	Concentration	Comments
Peroxyacetic acid	100 ppm	Up to 24 hours
Peroxyacetic acid	500 - 2000 ppm	1-4 days
Hydrogen peroxide	500 - 2000 ppm	4 days - 1 month Refresh solutions every 7 days
Citric acid / $K_2S_2O_5$	1000 - 2000 ppm	Up to 30 days
Nitrogen blanket	Pure - pressure 1 - 1.5 barg	Up to 30 days Check pressure regularly

## Chemical regeneration at high dP (blocked cartridges)

### When dP is above 1 bar over the filter stage

Some filters could be regenerated by a strong chemical clean. This can only be used on Polypropylene type filters (PEPLYN range) and the PES type filters (BEVPOR P/M range).

Cleaning frequency should be based on time or blockage. As blockage occurs exponentially, filters should be cleaned before rapid, unrecoverable blockage occurs, therefore, a strong chemical cleaning procedure (when the dP over the filter stage at process flow rate above 1 bar) might not work to regenerate the filters.

- CIP procedure using regeneration solution. Use gentle flow of solution in forward direction to minimize the dP over the filter stage during the cleaning procedure.



OR

- Remove cartridges from their housings, remove o-rings and place the cartridges in a bath of regeneration solution and agitate regularly.

Solution	Concentration	Comments
Phosphoric acid	1% at 55 °C	Example 1 Effective in removing all alkaline hardness (calcium carbonate)
Nitric acid	1 % at 55 °C	Example 2 Also used in cleaning filters with iron oxide deposits and colloidal iron
Sodium hydroxide	0.5 M (2 %) at 60 °C	Example 3 Effective in removing soluble components
Proprietary cleaners	As manufacturers' instructions	Check with Parker domnick hunter prior to use
Specific enzymes	As manufacturers' instructions	Expensive and only effective against specific contamination

# Regeneration examples

## Example 1 - BEVPOR PH - water filtration

Figure	Observation / comment
	<p>BEVPOR P filter blocked with a cake of fine organic solids (with calcium, magnesium and iron) coated on the surface.</p> <p>Pictures show the impact of the acid cleaning on the PES membrane.</p>
	<p>The membrane is soaked in 1 % phosphoric acid, the cake dissolved and the pores were visible. dP was reduced to clean dP. See picture on left - Interaction of phosphoric acid with the blocking material (left) (magnification 200)</p>

## Example 2 - PEPLYN HA - water filtration

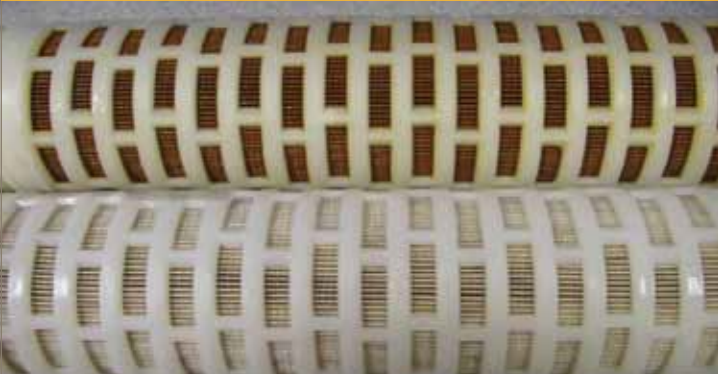
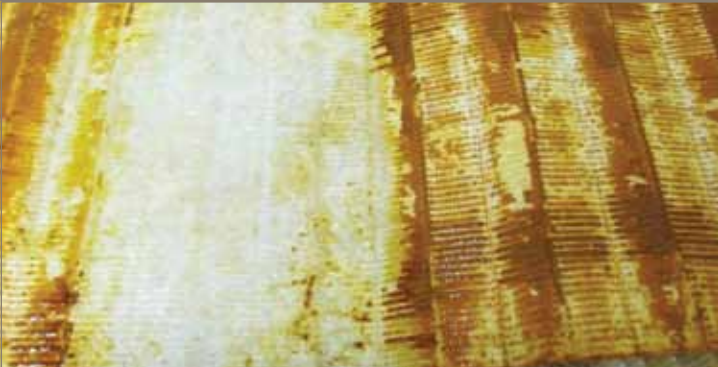
Figure	Observation / comment
	<p>Blockage material: Ion oxides.</p> <p>Cleaning regime carried out when dP reached 1 bar. 1 - 2% phosphoric acid solution mixed at 60 °C. The filters are placed in the solution as it cools and agitated occasionally over 24 hours before re-installation.</p>
	<p>Detail of cleaning effect on polypropylene media.</p>

## Example 3 - PREPOR PP- wine filtration

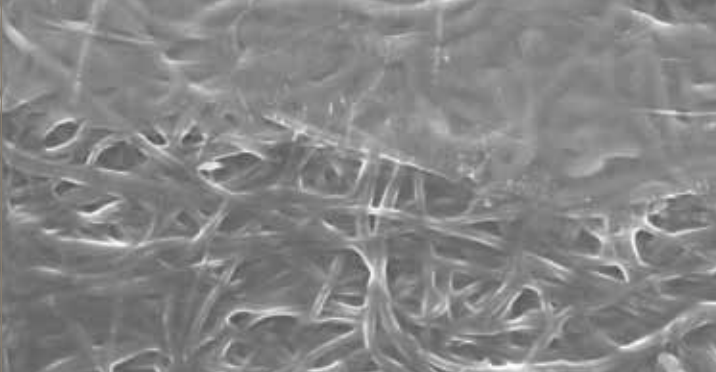
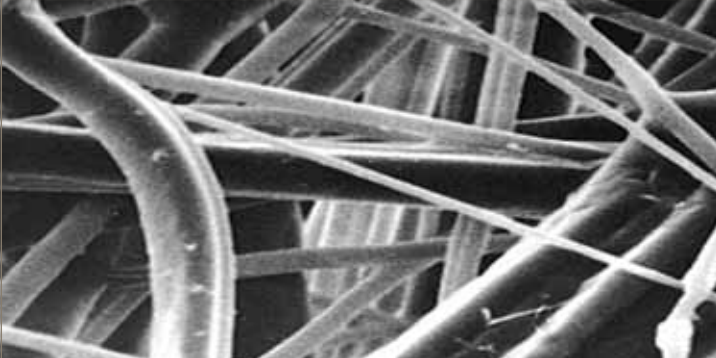
Figure	Observation / comment
	<p>PREPOR PP wine filter was blocked with CMC. Cleaning regime incorporating a 10 minute 0.5 % caustic clean was effective in regenerating the filters. It is suggested that this is performed on a weekly routine basis, but also when wines with high FI / high levels of CMC are filtered in error, or when a high dP (1 bar) is observed (which is not effectively reduced by hot water cleaning)</p>
	<p>Clean PREPOR PP media as reference</p>

## CIP approach

This section describes the effectiveness of a chemical type to a certain contaminant for performing CIP. The information is summarized in the table below.

Contaminant	CIP technique					
	Backflush water	Hot water	Alkali	Acid	Disinfectant / oxidant	Enzymes
Debris (sediment)	■					
Debris (organic)	■	■	■	■	■	
Diatomaceous Earth	■					
Finings (PVPP)	■					
Micro-organisms	■	■	■		■	
Scale [Ca, Mg-carbonates, phosphates]				■		
Colloidal complexes				■		
Fats			■			■
Proteins			■	■	■	■
Polysaccharides			■	■		
Acids			■			
CMC			■			
Tannins			■		■	

# Process simulations

The following process simulations have been carried out for BEVPOR P cartridges. The table below shows the simulated process CIP, details on chemical, concentration and temperature, filter type and recommended maximum number of cycles.

Active agent	Condition	Parker domnick hunter product	Guideline cumulative contact time
PAA hot water steam	1500ppm Peracetic acid (flush for 30 minutes) 80 °C hot water (flush for 30 minutes) steam @ 130°C	BEVPOR	30 cycles <sup>1</sup>
Hot water NaOH/KOH/H <sub>2</sub> O <sub>2</sub>	Hot water 80 °C for 30 minutes 1.25 % caustic for 10 minutes 0.08% Hydrogen Peroxide for 10 minutes (0.02 % AA and 0.02 % PAA)	BEVPOR	> 60 cycles <sup>2</sup>

References: <sup>1</sup> = T9050 / T9051

<sup>2</sup> = T10462

## Technical Support Group activities

Parker domnick hunter have a trained team of scientists and engineers available to answer questions regarding the technical capabilities of our products, to assist in the selection and design of appropriate filtration systems and to provide user training programs. The following services can be delivered both on-site and in-house:

- Filterability testing to optimize filter system design
- Advice on the development of integrity testing, steam sterilization and clean-in-place procedures
- Development of validation protocols
- Troubleshooting
- Facility audits to ensure continued optimization of filter use
- Operator training including filtration theory, validation, filter system design and management

For more information on any of the above support services please contact your local Parker domnick hunter representative.

email: [tsg@parker.com](mailto:tsg@parker.com)

website: [www.parker.com/processfiltration](http://www.parker.com/processfiltration)



# Parker Worldwide

## Europe, Middle East, Africa

**AE – United Arab Emirates,** Dubai  
Tel: +971 4 8127100  
parker.me@parker.com

**AT – Austria,** Wiener Neustadt  
Tel: +43 (0)2622 23501-0  
parker.austria@parker.com

**AT – Eastern Europe,** Wiener Neustadt  
Tel: +43 (0)2622 23501 900  
parker.easteurope@parker.com

**AZ – Azerbaijan,** Baku  
Tel: +994 50 2233 458  
parker.azerbaijan@parker.com

**BE/LU – Belgium,** Nivelles  
Tel: +32 (0)67 280 900  
parker.belgium@parker.com

**BY – Belarus,** Minsk  
Tel: +375 17 209 9399  
parker.belarus@parker.com

**CH – Switzerland,** Etoy  
Tel: +41 (0)21 821 87 00  
parker.switzerland@parker.com

**CZ – Czech Republic,** Klecany  
Tel: +420 284 083 111  
parker.czechrepublic@parker.com

**DE – Germany,** Kaarst  
Tel: +49 (0)2131 4016 0  
parker.germany@parker.com

**DK – Denmark,** Ballerup  
Tel: +45 43 56 04 00  
parker.denmark@parker.com

**ES – Spain,** Madrid  
Tel: +34 902 330 001  
parker.spain@parker.com

**FI – Finland,** Vantaa  
Tel: +358 (0)20 753 2500  
parker.finland@parker.com

**FR – France,** Contamine s/Arve  
Tel: +33 (0)4 50 25 80 25  
parker.france@parker.com

**GR – Greece,** Athens  
Tel: +30 210 933 6450  
parker.greece@parker.com

**HU – Hungary,** Budapest  
Tel: +36 1 220 4155  
parker.hungary@parker.com

**IE – Ireland,** Dublin  
Tel: +353 (0)1 466 6370  
parker.ireland@parker.com

**IT – Italy,** Corsico (MI)  
Tel: +39 02 45 19 21  
parker.italy@parker.com

**KZ – Kazakhstan,** Almaty  
Tel: +7 7272 505 800  
parker.easteurope@parker.com

**NL – The Netherlands,** Oldenzaal  
Tel: +31 (0)541 585 000  
parker.nl@parker.com

**NO – Norway,** Asker  
Tel: +47 66 75 34 00  
parker.norway@parker.com

**PL – Poland,** Warsaw  
Tel: +48 (0)22 573 24 00  
parker.poland@parker.com

**PT – Portugal,** Leca da Palmeira  
Tel: +351 22 999 7360  
parker.portugal@parker.com

**RO – Romania,** Bucharest  
Tel: +40 21 252 1382  
parker.romania@parker.com

**RU – Russia,** Moscow  
Tel: +7 495 645-2156  
parker.russia@parker.com

**SE – Sweden,** Spånga  
Tel: +46 (0)8 59 79 50 00  
parker.sweden@parker.com

**SK – Slovakia,** Banská Bystrica  
Tel: +421 484 162 252  
parker.slovakia@parker.com

**SL – Slovenia,** Novo Mesto  
Tel: +386 7 337 6650  
parker.slovenia@parker.com

**TR – Turkey,** Istanbul  
Tel: +90 216 4997081  
parker.turkey@parker.com

**UA – Ukraine,** Kiev  
Tel: +380 44 494 2731  
parker.ukraine@parker.com

**UK – United Kingdom,** Warwick  
Tel: +44 (0)1926 317 878  
parker.uk@parker.com

**ZA – South Africa,** Kempton Park  
Tel: +27 (0)11 961 0700  
parker.southafrica@parker.com

## North America

**CA – Canada,** Milton, Ontario  
Tel: +1 905 693 3000

**US – USA,** Cleveland  
Tel: +1 216 896 3000

## Asia Pacific

**AU – Australia,** Castle Hill  
Tel: +61 (0)2-9634 7777

**CN – China,** Shanghai  
Tel: +86 21 2899 5000

**HK – Hong Kong**  
Tel: +852 2428 8008

**IN – India,** Mumbai  
Tel: +91 22 6513 7081-85

**JP – Japan,** Tokyo  
Tel: +81 (0)3 6408 3901

**KR – South Korea,** Seoul  
Tel: +82 2 559 0400

**MY – Malaysia,** Shah Alam  
Tel: +60 3 7849 0800

**NZ – New Zealand,** Mt Wellington  
Tel: +64 9 574 1744

**SG – Singapore**  
Tel: +65 6887 6300

**TH – Thailand,** Bangkok  
Tel: +662 717 8140

**TW – Taiwan,** Taipei  
Tel: +886 2 2298 8987

## South America

**AR – Argentina,** Buenos Aires  
Tel: +54 3327 44 4129

**BR – Brazil,** Sao Jose dos Campos  
Tel: +55 12 4009 3500

**CL – Chile,** Santiago  
Tel: +56 2 623 1216

**MX – Mexico,** Apodaca  
Tel: +52 81 8156 6000

**VE – Venezuela,** Caracas  
Tel: +58 212 238 5422